

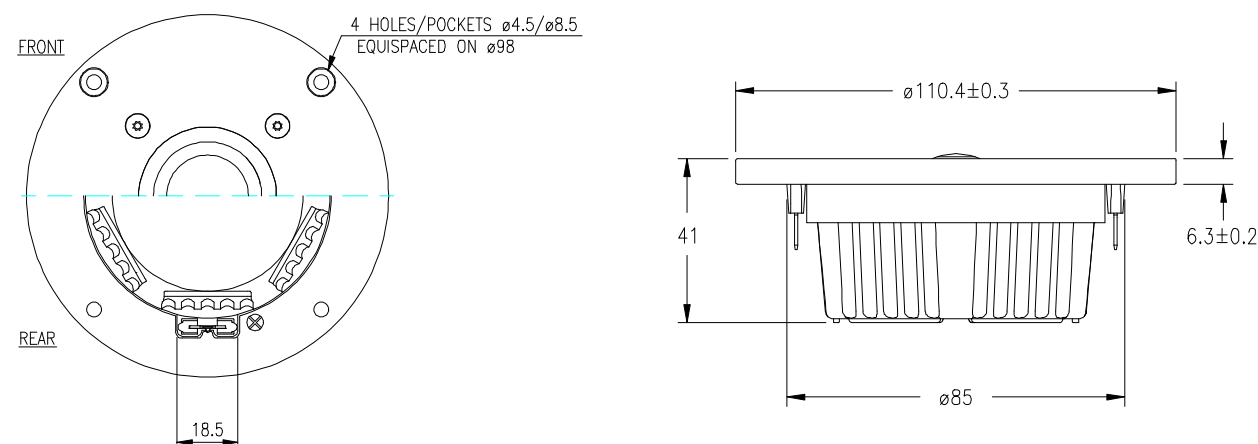

MILLENNIUM TWEETER T25CF002 E 011



The T25CF-002, "MILLENNIUM" is a 25mm soft dome tweeter with a novel Neodymium based magnet system.

It is the tweeter of choice for those who seek extremely precise and realistic sound reproduction combined with a relatively low crossover frequency.

SPECIAL FEATURES

A unique HEXADYM magnet system (patent applied for) based on 6 radially magnetized NdFeB magnet blocks. Efficient ventilation and damping of every potentially resonant cavity behind the dome, surround and voice coil. Moderate magnetic stray fields present no problems in AV installations.

A generously underhung voice coil (+ and - 0.5mm) ensures low distortion even with low crossover frequencies.

An optimally shaped and coated fabric dome diaphragm manufactured by SEAS from SONOTEX for excellent performance and consistency.

A homogenous, linear surround manufactured by SEAS from SONOMAX, a soft polymer material of high climatic stability.

Flexible lead-out wires which ensure a good connection between voice coil and terminals. This arrangement also helps to prevent lead breakage due to the large excursions encountered when low crossover frequencies are used.

Low viscosity magnetic fluid which provides excellent cooling while maintaining a low resonance frequency.

6,0 mm injection moulded zinc front plate with a very slight loading characteristic which ensures linear frequency response, and a stiff and stable connection to the cabinet.

A substantial injection-moulded rear chamber made from zinc eliminates unwanted chamber wall resonances and conducts heat away from the magnet system.

NOMINAL IMPEDANCE	6 Ohms	VOICE COIL RESISTANCE	4,7 Ohms
RECOMMENDED FREQUENCY RANGE	2000-2500Hz	VOICE COIL INDUCTANCE (EQUIVALENT)	0,05 mH
SHORT TERM MAXIMUM POWER*	200 W	VOICE COIL DIAMETER	26 mm
LONG TERM MAXIMUM POWER*	90 W	VOICE COIL HEIGHT	1,5 mm
CHARACTERISTIC SENSITIVITY (1W,1m)	88 dB SPL	MOVING MASS	0,37 g
OPERATING POWER (96 dB SPL , 1m)	6,3 W	EFFECTIVE PISTON AREA	7,0 sq.cm
AIR GAP HEIGHT	2,5 mm	LINEAR COIL TRAVEL (p-p)	1,0 mm
MAGNETIC GAP FLUX DENSITY	1,5 T	FREE AIR RESONANCE	500 Hz
FORCE FACTOR	3,1 N/A		
MAGNET WEIGHT	29 g		
TOTAL WEIGHT	0,36 Kg		

* IEC 268-5, VIA HIGH PASS BUTTERWORTH FILTER: 2500 Hz 12 dB/oct.

Response curve recorded in an anechoic chamber (Free-field, 4 pi radiation) with 0.5m microphone distance. The loudspeaker is mounted in a 0.6m by 0.8m baffle.

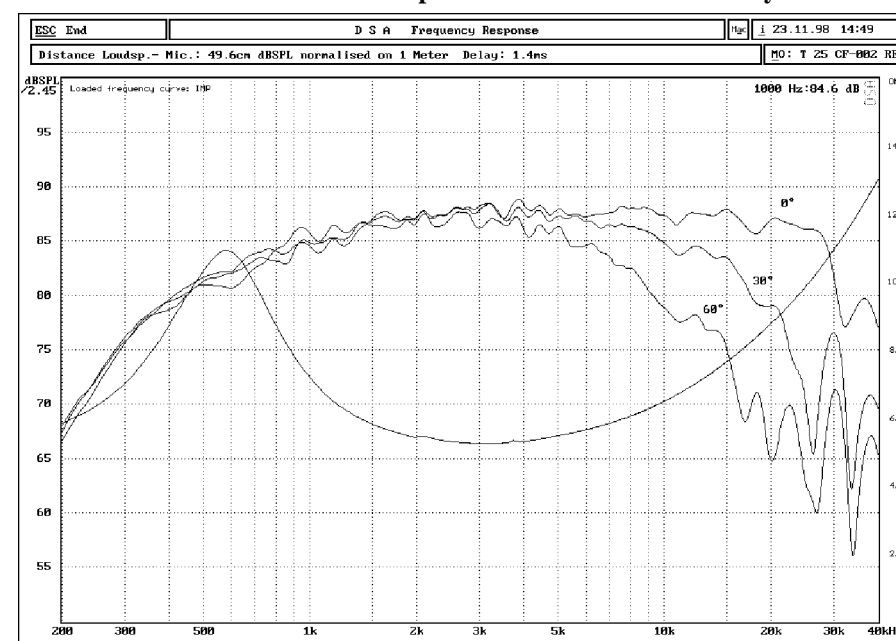

Cumulative spectral decay

